

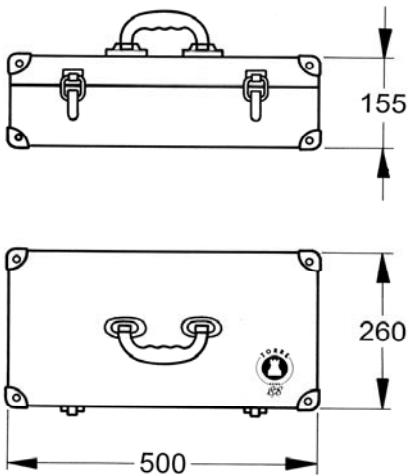

GOLF KIT

universal drilling kit for branching saddles

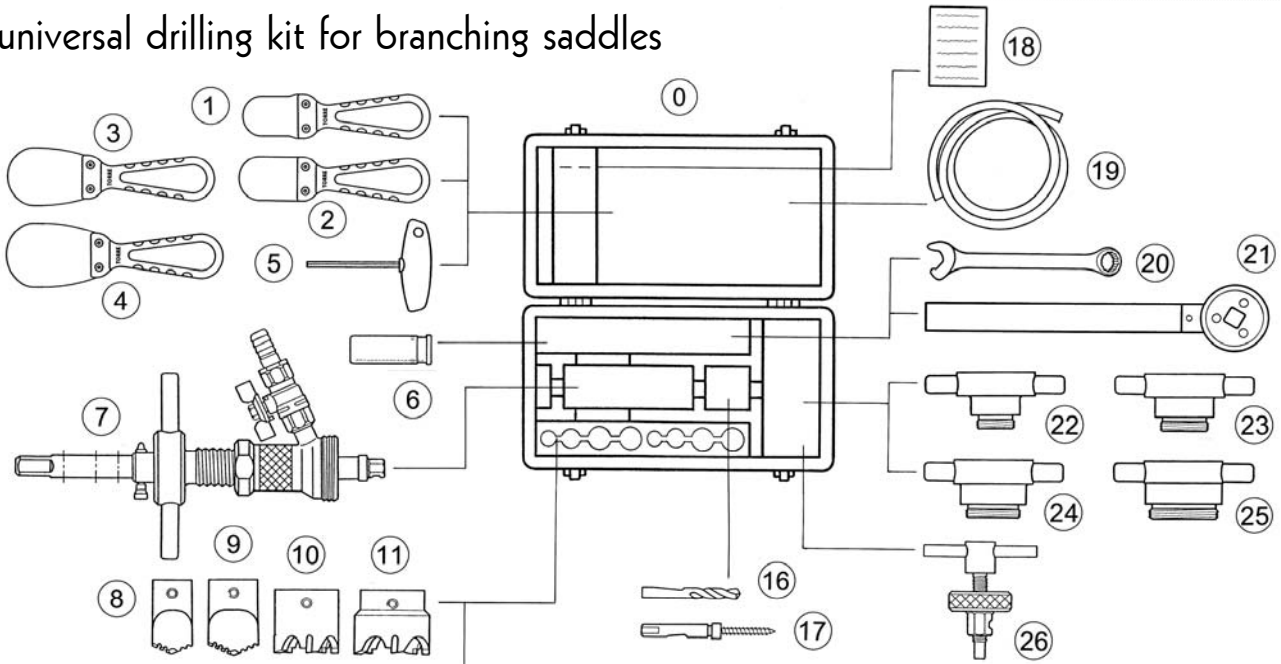

interTORRE

Selva de Mar 135-145 ● 08020 Barcelona ● Spain
 Tel. 93 307 31 60 ● Fax 93 307 35 08
 promo@torre.biz ● www.torre.biz

GOLF KIT COMPONENTS

Nº, NAME REFERENCE AND QUANTITIES

Nº	NAME	REFERENCE	QUANTITY
0	Empty tool box	2110 C 02	1
1	1" Spatula	1256	1
2	1¼" Spatula	1257	1
3	1½" Spatula	1258	1
4	2" Spatula	1259	1
5	T-handle hex key of 3mm	1657	1
6	Spare parts box:		1
	- Pin with elastic ring	1093	1
	- Elastic ring for pin	1108	2
	- O-ring (21 x 3)	JT21X3	2
	- Stainless steel stud bolts	--	12
7	Drilling machine 4 positions	1961	1
8	Integral drill 1"	2385 B 24	1
9	Integral drill 1¼"	2385 B 30	1
10	Cutter FDW 1½"	2385 FDW 38	1
11	Cutter FDW 2"	2385 FDW 44	1
12	Cutter PE/PVC 1"	2385 PEC 23	1
13	Cutter PE/PVC 1¼"	2385 PEC 29	1
14	Cutter PE/PVC 1½"	2385 PEC 37	1
15	Cutter PE/PVC 2"	2385 PEC 43	1
16	Centering drill 6,3 mm diam.	2385 B 6	2
17	Retaining screw for PVC	2385 T 4	2
18	Check List	--	1
19	Drainage hose (2 meters)	1043	1
20	Combination grip wrench of 19	1940	1
21	17 mm Ratchet wrench	2481 D	1
22	1" Coupling	1936	1
23	1¼" Coupling	1937	1
24	1½" Coupling	1938	1
25	2" Coupling	1939	1
26	Core extractor PE/PVC of 15	1042	1

WEIGHT KIT: 11,5 Kg.

