

DRILLING EQUIPMENT for gas

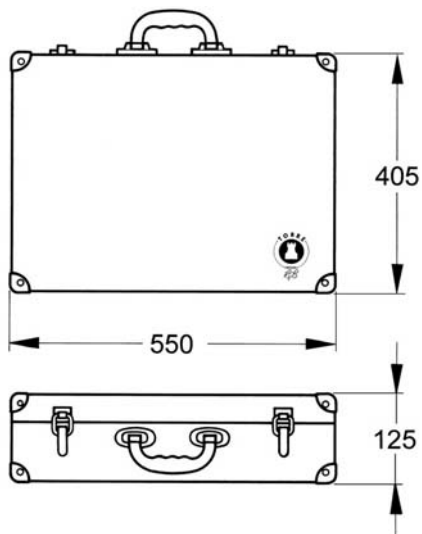
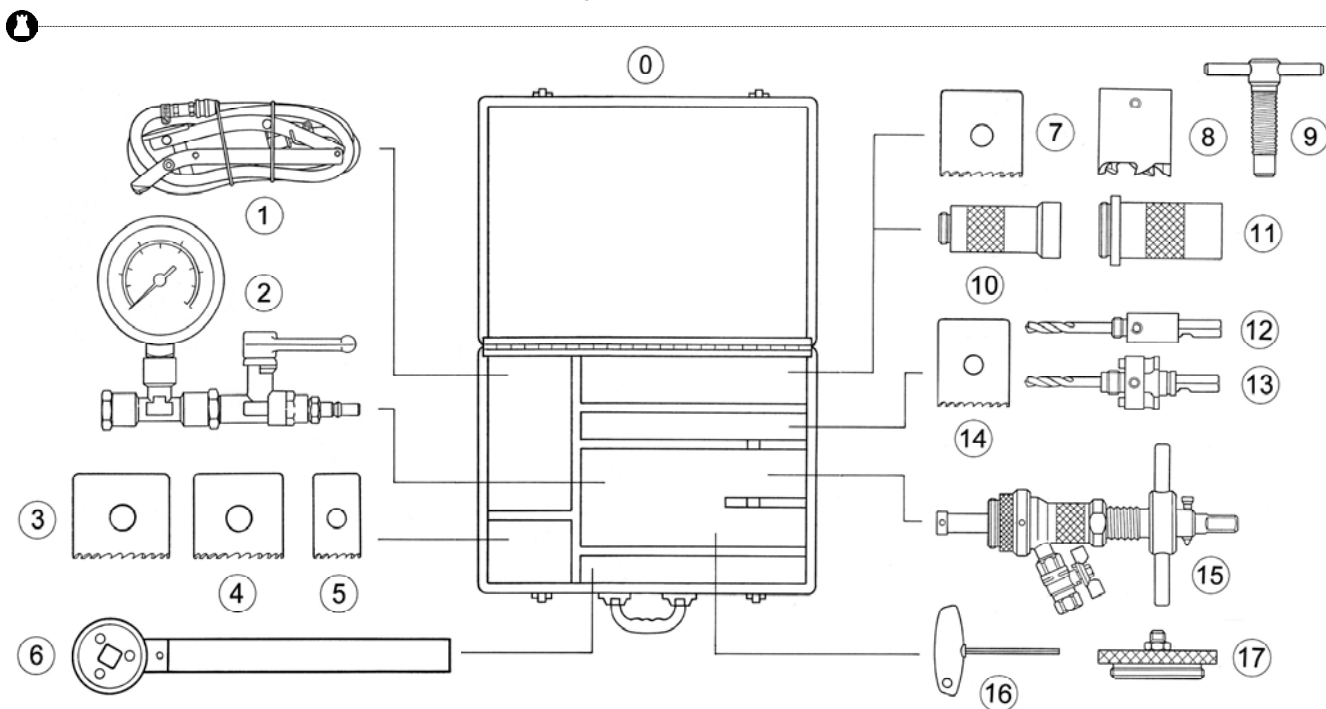

DRILLING EQUIPMENT COMPONENTS

Nº, NAME, REFERENCE AND QUANTITIES

Nº	NAME	REFERENCE	C *	B *
0	Empty tool box	2115 C 01	1	1
1	Foot pump kit	1146	1	1
2	EP manometer kit	1148	1	1
3	ø 51 Starrett Cutter	1145	1	--
4	ø 48 Starrett Cutter	1144	1	--
5	ø 25 Starrett Cutter	1141	1	--
6	17 mm Ratchet wrench	2481 D	1	1
7	ø 43 Starrett Cutter	1143	1	1
8	ø 42 PE Cutter	9306	1	1
9	Core extractor PE ø 42 cutter	1194	1	1
10	1" EP Adapter	9261	1	--
11	2" EP Adapter	9262	1	--
12	Small cutter holder kit	1140	1	--
13	Big cutter holder kit	1139	1	--
14	ø 38 Starrett Cutter	1142	1	1
15	Drilling machine	1138	1	1
16	T-handle Hex Key of 3 mm.	1137	1	1
17	EP Test cover	1147	1	1

* C: Complete version quantities
B: Basic version quantities



interTORRE

Selva de Mar 135-145 ● 08020 Barcelona ● Spain
Tel. 93 307 31 60 ● Fax 93 307 35 08
promo@torre.biz ● www.torre.biz