

## SARCO 'SUPRA' SELF-CENTRING GAS BAGS



Standard nominal pipe sizes 75mm - 300mm  
**Maximum main pressure 2 bar specification.**  
 Self-centring, spined with special 'Kevlar' pressure joints. The bags meet the E19 & E20 technical requirements for higher pressure applications.

### Latex Outer Skin Bags

In order to provide a virtually zero bypass past the bag an outer latex skin, chlorinated to provide added protection and enhanced launching and sealing performance is added to the basic 'Supra' bag design.

### 1 Bar 'Supra' Single Bag Option

The double cover spined bag is provided in fluorescent orange.

### Larger bags up to 2400mm in size

produced in various shapes to suit customer applications and methods of deployment.

## BAGGING-OFF EQUIPMENT (GAS) SARCO 'RESISTRA' BAG STOPPER BGES/E4 SPECIFICATION

Inflatable self-centring bag stoppers with central spine & outer PU coated nylon cover in high visibility yellow.

### Operational Data

Before commencing a flow-stopping operation, it is recommended that reference is made to industry Codes of Practice for bagging-off gas mains to ascertain limiting pressures, allowable tappings, dimensions etc. which may override any information given below:

Larger bag sizes up to 96" (750mm) made to suit customer requirements and method of deployment.

Nominal size of main	PE	(mm)	63	125	180	250	315	355	400
	Ferrous	(in)	2	3/4	5/6	7/8	9/10	12	16
		(mm)	50	80/100	150	200	250	300	400
Max allowable main pressure	PE	(psi)	4	4	4	3	1.5	1.5	1.5
	Ferrous	(mbar)	300	300	300	200	100	100	100
		(psi)	5	5	4	4	3	1.5	1.5
Min distance from secondary tapping to primary tapping to bypass tapping	PE	(in)	18	18	20	22	24	24	26
		(mm)	450	450	500	550	600	600	650
	Ferrous	(in)	16	16	18	20	22	24	26
(mm)		400	400	450	500	550	600	650	
Cut hole diameter	PE	(mm)	56	56	56	56	56	56	56
Tapping size BSP parallel thread to BS21	Ferrous	(in)	1	1	1 1/2	1 1/2(7), 2(8)	2	2	2
Bag inflation Pressure	PE	(psi)	15	8	8	5	4	4	3
		(mbar)	1000	550	550	350	300	300	200
	Ferrous	(psi)	15	10	8	8	5	4	3
(mbar)		1000	700	550	550	350	300	200	

DISTRIBUTED BY:

BROCKS WAY ● EAST MAINS INDUSTRIAL ESTATE  
 BROXBURN ● NR EDINBURGH  
 WEST LOTHIAN ● EH52 5NB ● SCOTLAND  
 TEL: +44 (0) 1506 855824  
 FAX: +44 (0) 1506 855849  
 EMAIL: mail@sarcostopper.com  
 WEBSITE: www.sarcostopper.com

## RESISTRA ● SUPRA ● ULTRA ● INSPECTRA GAS BAGS



UNDER PRESSURE SINGLE & TWIN BAGGING  
 OFF SYSTEMS FOR P.E. & FERROUS GAS  
 PIPELINES

**SARCO**  
**STOPPER**  
 LIMITED

UVDB  
 UTILITIES VENDOR DATABASE

sbg  
 sbgi

**SARCO**  
**STOPPER**  
 LIMITED

# UNDER PRESSURE SINGLE & TWIN BAGGING-OFF SYSTEMS FOR P.E. & FERROUS GAS PIPELINES

## BGES/E4 BAG STOPPER



Under pressure drilling machines, bypass & bagging-off equipment manufactured by WASK recognised as world wide leaders in the sector and who recommend use of only Sarco gas bag stoppers with their range of equipment.

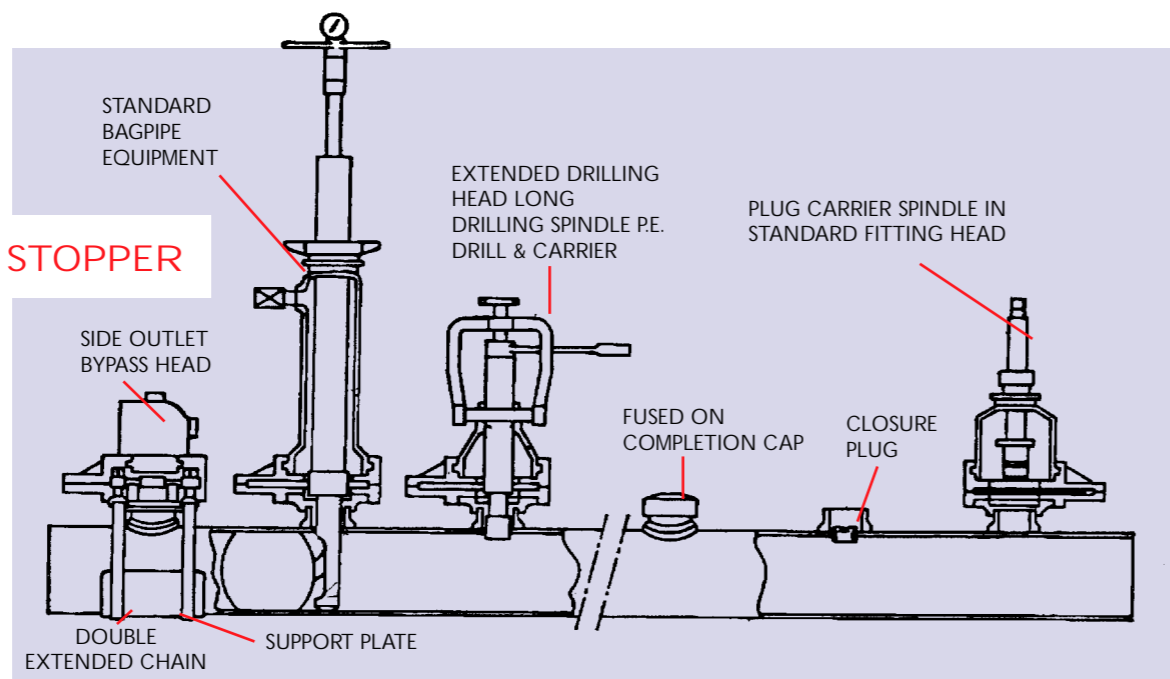

### Design and Performance

The Bagging-off Equipment provides a safe and comprehensive method of flow-stopping polyethylene (125mm to 400mm), ferrous 3" to 12" cast iron, 80mm to 400mm ductile iron live gas mains under gas free working conditions. The equipment comprises a Canopy enclosing the Bag tube which is mounted on the Universal Base, enabling a Stopper Bag to be inserted through a tapping into the main and inflated to stop the flow of gas. Sets of interchangeable Noses and Shoes permit the Stopper Bag to be correctly positioned relative to the centre of the main and positive support of the inflated Stopper Bag against the gas. *Operational data shown on the back page of this brochure.*

## SARCO 'RESISTRA' SELF CENTRING GAS BAGS

Designed specifically for under pressure bagging-off

Standard nominal pipe sizes 50mm - 450mm

### Maximum main pressure 350Mbar specification

The stopper bag conforms fully to the British Gas Engineering specification BGES/E4 for inflatable self-centring bags for use on distribution mains.

The bag is constructed from natural latex rubber bladders an outer cover of high strength polyurethane coated nylon in high visibility yellow and central semi rigid spine with 1/2" UNF female connector.

Approved by National Grid  
Transco Engineering

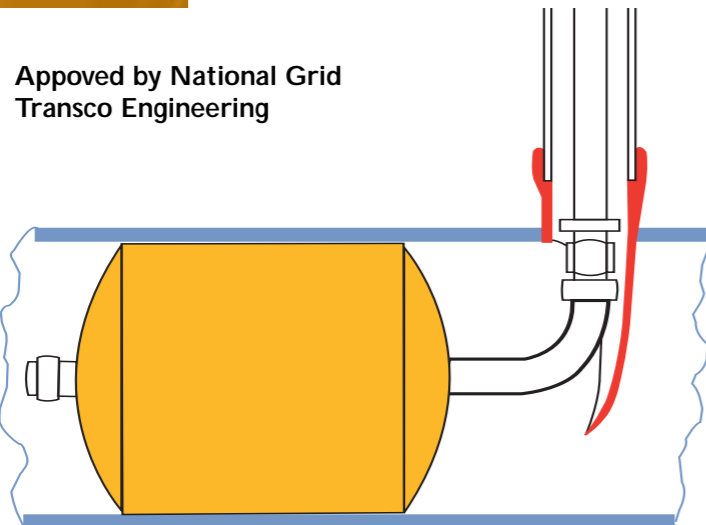

All bags are individually factory tested. Bags have a life of 30 months (if stored in boxes out of direct sunlight and below 25C).

**400 Mbar Gas Bag Range** similar to BGES/E4 construction is also available in fluorescent orange. Standard nominal pipe sizes 50mm - 450mm  
**Maximum main pressure 400Mbar.**

## 'INSPECTRA' TWIN BAG MULTI SERVICE SPINE

### Lower cost leakage measurement system.

Incorporated twin self-centring BGES/E4 gas bags with multi service core spines (up to 9 separate services can be accommodated). Provide a low cost leakage measurement system for pipe lines. Developed with B.G. Technology Pipeline Services. **The system provides a number of solutions:**

- Intelligent double bag seal isolates test section. Control of inter-bag pressure gives a 'virtual' seal.
- D/4 access - avoids output and bypass operations.
- Laptop PC controls both ends and logs pressure drop data - automated data collection.
- Enables low cost medium pressure and larger diameter testing.



**BG Technology**  
Pipeline Services

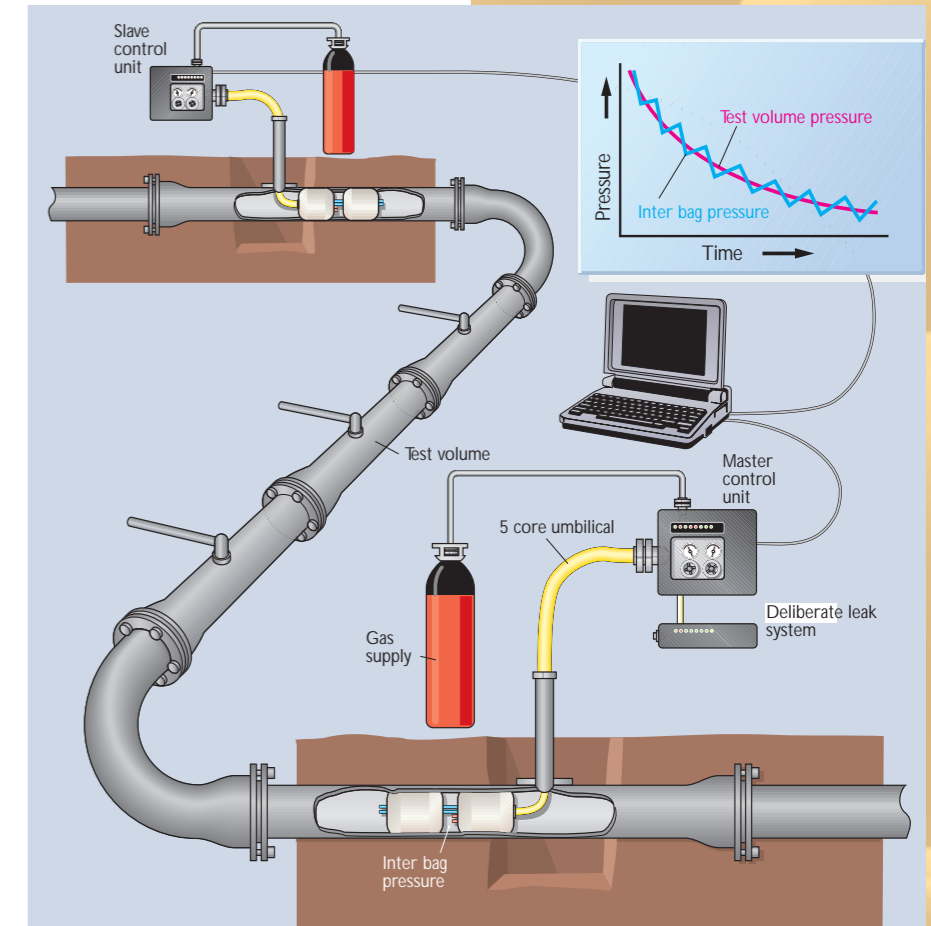

## BAGGING-OFF POLYETHYLENE MAINS

Bagging-off P.E. mains can be a more efficient method of flow stopping than the alternative "squeeze off" technique, particularly where larger diameters demand double units each side of the working area. (Size range 125mm - 400mm)

### The resulting benefits are:

- Lower cost due to less ground removal and consequential re- instatement.
- The operation can take place in a smaller working area therefore creating less disturbance in urban areas.
- No damage is done to the PE pipe.
- Cost and time saving as no re-rounding of the pipe is required.



## SARCO 'ULTRA' TWIN BAG SINGLE ENTRY GAS BAGS

Standard nominal pipe sizes 75mm - 400mm.

**Maximum main pressure 350Mbar.** Using twin BGES/E4 type bags but incorporating a 4 service core spine. A single entry bagging-off system is provided and reduces costs of more traditional bagging-off techniques.

- Minimum dig solution
- Reduced traffic & other disruptions
- Avoidance of multi pipe entry alternatives
- Reduced reinstatement costs
- Modular gas bag options.
- Reduced lane rental charges

